

PT	Instruções para uso / Manual de Instalação	2
ES	Modo de empleo / Instrucciones de montaje	3
EN	Instructions for use / Assembly instructions	4
FR	Mode d'emploi / Instructions de montage	5
DE	Gebrauchsanleitung / Montageanleitung	6

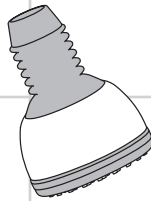

Croma 75 1-Jet
26730000

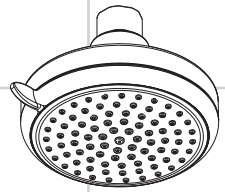

Croma 100 Variojet
26731000

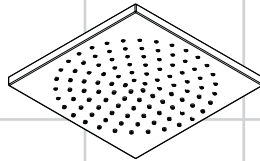

Square 180
26732000

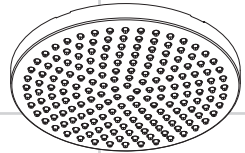

Croma 160
26733000

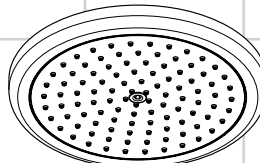

Croma 220
26734000

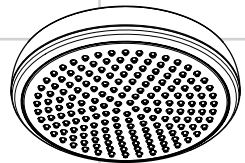

Crometta 160
26576000
26576400



Avisos de segurança

- ⚠ Durante a montagem devem ser utilizadas luvas de protecção, de modo a evitar ferimentos resultantes de entalamentos e de cortes.
- ⚠ O sistema de duche só pode ser utilizado para fins de higiene pessoal.
- ⚠ Crianças e adultos com deficiências motoras, mentais e/ou sensoriais não podem utilizar o sistema de duche sem monitorização. Pessoas que estejam sob a influência de álcool ou drogas não podem utilizar o sistema de duche.
- ⚠ Deve-se evitar o contacto dos jactos de água com partes do corpo sensíveis (p. ex. olhos). É necessário manter uma distância suficiente entre o chuveiro e o corpo.

Avisos de montagem

- Antes da montagem deve-se controlar o produto relativamente a danos de transporte. Após a montagem não são aceites quaisquer danos de transporte ou de superfície.
- As tubagens e a torneira têm que ser montadas, enxaguadas e verificadas de acordo com as normas em vigor.
- A prescrições de instalação válidas nos respetivos países devem ser respeitadas.
- O coletor de sujidade/impurezas pré-montado tem que ser utilizado, de modo a evitar o enxaguamento de sujidade proveniente da rede de água. A sujidade proveniente da rede pode influenciar o funcionamento e/ou provocar danos nas peças funcionais do equipamento. A Hansgrohe não se responsabiliza por danos daí resultantes.

Dados Técnicos

Pressão de funcionamento: max. 0,6 MPa
Pressão de funcionamento anterior à chuveiro fixo: 0,02 - 0,15 MPa
(1 MPa = 10 bar = 147 PSI)
Temperatura da água quente: max. 60°C
Desinfecção térmica: max. 70°C / 4 min
Este produto foi única e exclusivamente concebido para água potável!

Descrição do símbolo



Não utilizar silicone que contenha ácido acético!



Medidas (ver página 7)



Fluxograma (ver página 8)



Limpeza (ver página 11 e brochura em anexo)







Peças de substituição (ver página 15)





Indicaciones de seguridad

-  Durante el montaje deben utilizarse guantes para evitar heridas por aplastamiento o corte.
-  El sistema de ducha solo debe ser utilizado para fines de baño, higiene y limpieza corporal.
-  Niños, así como adultos con limitaciones corporales, mentales y/o sensoriales no deben utilizar el sistema de duchas sin vigilancia. Personas que se encuentran bajo el efecto de alcohol o drogas, no deben utilizar el sistema de duchas.
-  Debe evitarse el contacto del chorro del pulverizador con partes sensibles del cuerpo (por ej. ojos).
-  Debe mantenerse una distancia suficiente entre pulverizador y cuerpo.

Indicaciones para el montaje

- Antes del montaje se debe examinarse el producto contra daños de transporte. Después de la instalación so se reconoce ningún daño de transporte o de superficie.
- Los conductos y la grifería deben montarse, lavarse y comprobarse según las normas vigentes.
- Es obligatorio el cumplimiento de las directrices de instalación vigentes en el país respectivo.
- El colector de suciedad premontado debe utilizarse para evitar que penetre la suciedad en la red de tuberías. La suciedad puede afectar el funcionamiento y/o provocar daños en partes funcionales del grifo. Hansgrohe no asume ninguna responsabilidad por los daños que de ello se deriven.

Datos técnicos

Presión en servicio: max. 0,6 MPa
 Presión de servicio delante de la ducha fija: 0,02 - 0,15 MPa
 (1 MPa = 10 bar = 147 PSI)
 Temperatura del agua caliente: max. 60°C
 Desinfección térmica: max. 70°C / 4 min
 El producto ha sido concebido exclusivamente para agua potable.

Descripción de símbolos



No utilizar silicona que contiene ácido acético!



Dimensiones (ver página 7)



Diagrama de circulación (ver página 8)



Limpiar (ver página 11 y folleto anexo)







Repuestos (ver página 15)





Safety Notes

-  Gloves should be worn during installation to prevent crushing and cutting injuries.
-  The shower system may only be used for bathing, hygienic and body cleaning purposes.
-  Children as well as adults with physical, mental and/or sensoric impairments must not use this shower system without proper supervision. Persons under the influence of alcohol or drugs are prohibited from using this shower system.
-  Do not allow the streams of the shower touch sensitive body parts (such as your eyes). An adequate distance must be kept between the shower and you.

Installation Instructions

- Prior to installation, inspect the product for transport damages. After it has been installed, no transport or surface damage will be honoured.
- The pipes and the fixture must be installed, flushed and tested as per the applicable standards.
- The plumbing codes applicable in the respective countries must be observed.
- The premounted dirt collection screen must be used to prevent dirt from entering through the pipes. Dirt entering can affect the function and/or lead to damage to the functional components of the fitting. Hansgrohe will not be held liable for any resulting damage.

Technical Data

Operating pressure: max. 0,6 MPa
Operating pressure in front of the shower: 0,02 - 0,15 MPa
(1 MPa = 10 bar = 147 PSI)
Hot water temperature: max. 60°C
Thermal disinfection: max. 70°C / 4 min
The product is exclusively designed for drinking water!

Symbol description



Do not use silicone containing acetic acid!



Dimensions (see page 7)



Flow diagram (see page 8)



Cleaning (see page 11 and enclosed brochure)







Spare parts (see page 15)





Consignes de sécurité

-  Lors du montage, porter des gants de protection pour éviter toute blessure par écrasement ou coupure.
-  Le système de douche ne doit servir qu'à se laver et à assurer l'hygiène corporelle.
-  Il est interdit aux enfants ainsi qu'aux adultes ayant des insuffisances physiques, psychiques et/ou motoriques d'utiliser la douche sans surveillance. De même, il est interdit à des personnes sous influence d'alcool ou de drogues d'utiliser la douche.
-  Éviter le contact du jet de la douchette avec les parties sensibles du corps (telles par ex. que les yeux). Veiller à respecter un écart suffisant entre la douchette et le corps.

Instructions pour le montage

- Avant son montage, s'assurer que le produit n'a subi aucun dommage pendant le transport. Après le montage, tout dommage de transport ou de surface ne pourra pas être reconnu.
- Les conduites et la robinetterie doivent être montés, rincés et contrôlés selon les normes en vigueur.
- Les directives d'installation en vigueur dans le pays concerné doivent être respectées.
- Le tamis prémonté doit être utilisé pour éviter aux saletés de s'infiltrer dans le réseau de conduites. Les saletés peuvent porter préjudice au fonctionnement et/ou provoquer des endommagements au niveau des éléments fonctionnels de la robinetterie, pour lesquels Hansgrohe n'engage aucune responsabilité.

Informations techniques

Pression de service autorisée:	max. 0,6 MPa
Pression de service devant la pomme de douche:	0,02 - 0,15 MPa
(1 MPa = 10 bar = 147 PSI)	
Température d'eau chaude:	max. 60°C
Désinfection thermique:	max. 70°C / 4 min
Le produit est exclusivement conçu pour de l'eau potable!	

Description du symbole



Ne pas utiliser de silicone contenant de l'acide acétique!



Dimensions (voir pages 7)



Diagramme du débit (voir pages 8)



Nettoyage (voir pages 11 et brochure ci-jointe)



Pièces détachées (voir pages 15)



Montage voir page 9



Sicherheitshinweise

- ⚠ Bei der Montage müssen zur Vermeidung von Quetsch- und Schnittverletzungen Handschuhe getragen werden.
- ⚠ Das Duschsystem darf nur zu Bade-, Hygiene- und Körperreinigungszwecken eingesetzt werden.
- ⚠ Kinder, sowie Erwachsene mit körperlichen, geistigen und / oder sensorischen Einschränkungen dürfen das Duschsystem nicht unbeaufsichtigt benutzen.
- ⚠ Personen, die unter Alkohol- oder Drogeneinfluss stehen, dürfen das Duschsystem nicht benutzen.
- ⚠ Der Kontakt der Brausestrahlen mit empfindlichen Körperstellen (z. B. Augen) muss vermieden werden.
- ⚠ Es muss ein ausreichender Abstand zwischen Brause und Körper eingehalten werden.

Montagehinweise

- Vor der Montage muss das Produkt auf Transportschäden untersucht werden. Nach dem Einbau werden keine Transport- oder Oberflächenschäden anerkannt.
- Die Leitungen und die Armatur müssen nach den gültigen Normen montiert, gespült und geprüft werden.
- Die in den Ländern jeweils gültigen Installationsrichtlinien sind einzuhalten.
- Das vormontierte Schmutzfangsieb muss verwendet werden, um Schmutzeinspülungen aus dem Leitungsnetz zu vermeiden. Schmutzeinspülungen können die Funktion beeinträchtigen und/oder zu Beschädigungen an Funktionsteilen der Armatur führen, für hieraus ergebende Schäden haftet Hansgrohe nicht.

Technische Daten

Betriebsdruck:	max. 0,6 MPa
Betriebsdruck vor der Brause: (1 MPa = 10 bar = 147 PSI)	0,02 - 0,15 MPa
Heißwassertemperatur:	max. 60°C
Thermische Desinfektion:	max. 70°C / 4 min
Das Produkt ist ausschließlich für Trinkwasser konzipiert!	

Symbolerklärung



Kein essigsäurehaltiges Silikon verwenden!



Maße (siehe Seite 7)



Durchflussdiagramm (siehe Seite 8)



Reinigung (siehe Seite 11 und beiliegende Broschüre)



Serviceteile (siehe Seite 15)



26730000

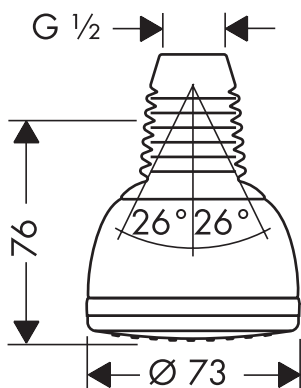

26733000

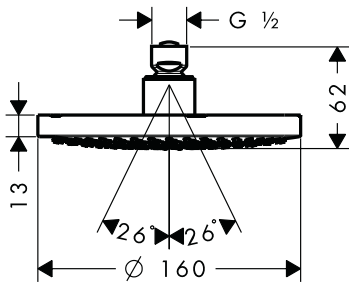

26732000

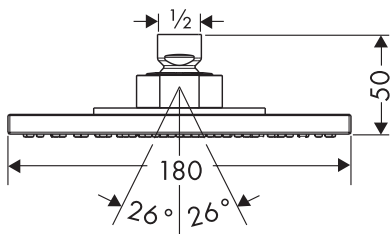

26734000

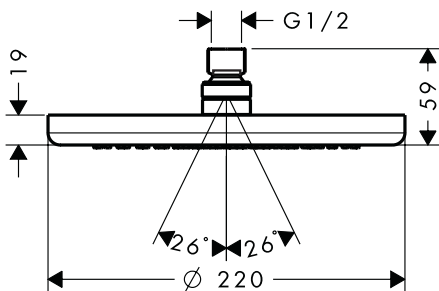

26731000

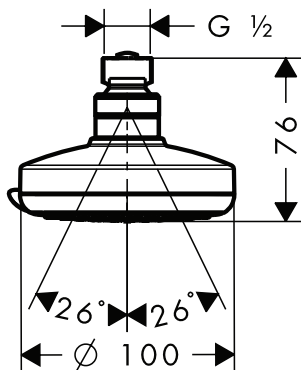

26576000 / 26576400

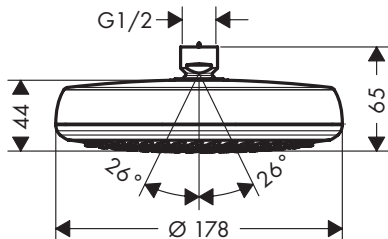



26730000

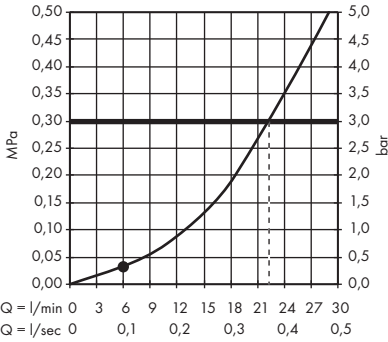

26733000

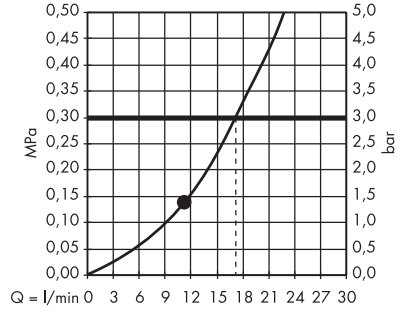

26732000

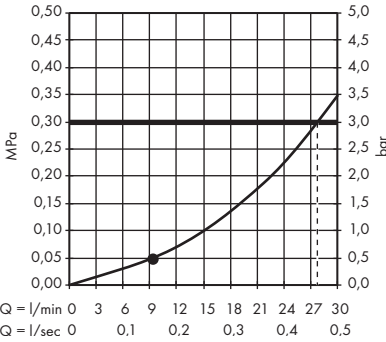

26734000

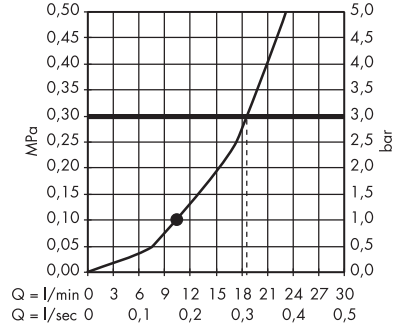

26731000

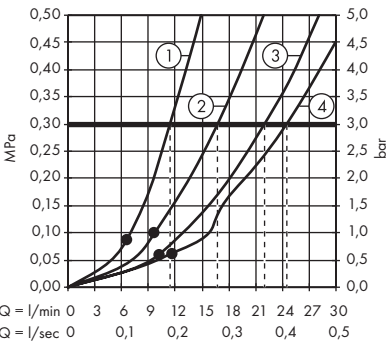

26576000 / 26576400

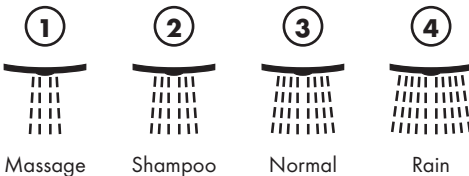
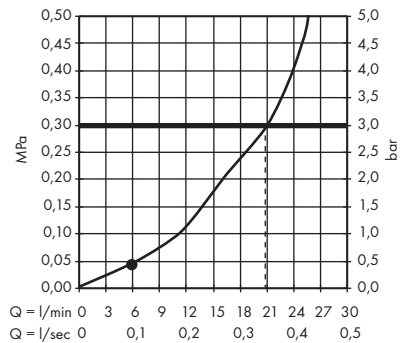

● A partir deste ponto inicia-se o funcionamento correcto.
Mínimo ● para el correcto funcionamiento.
From ● the function is guaranteed.
A partir de le fonctionnement est garanti.
Ab ● ist die Funktion gewährleistet.



26730000

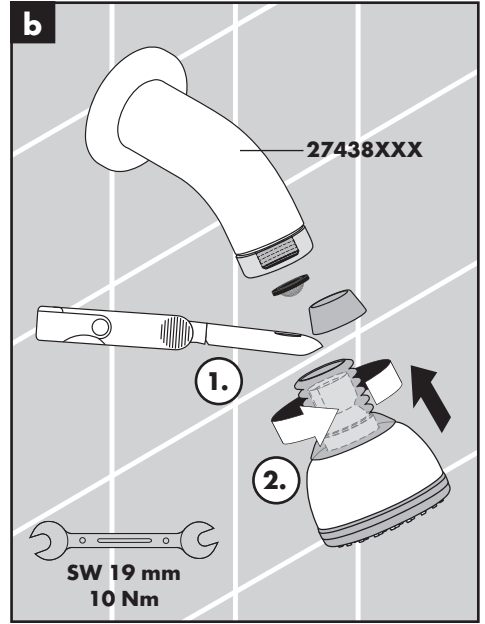
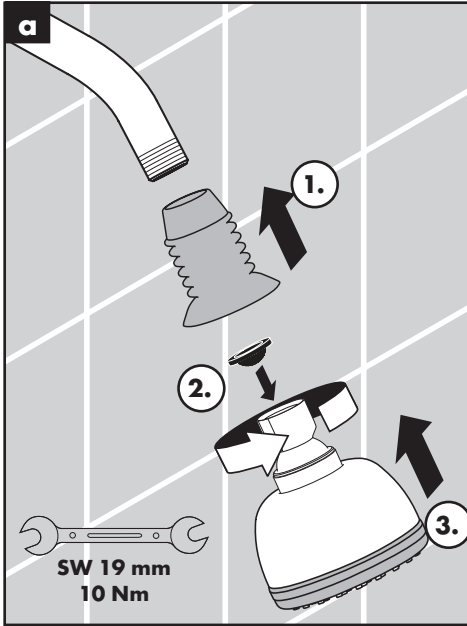

26731000 / 26732000 / 26733000 / 26734000 / 26576XX0

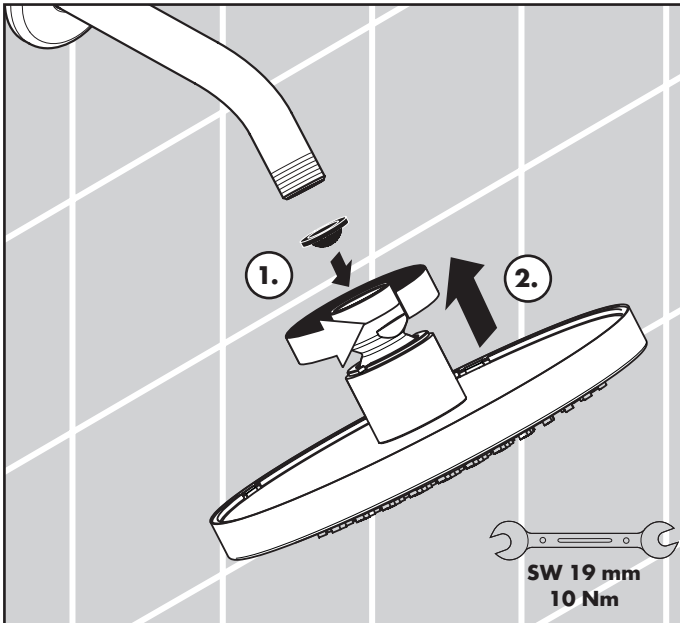



26730000 / 26731000 / 26732000 / 26733000 / 26734000 / 26576xx0

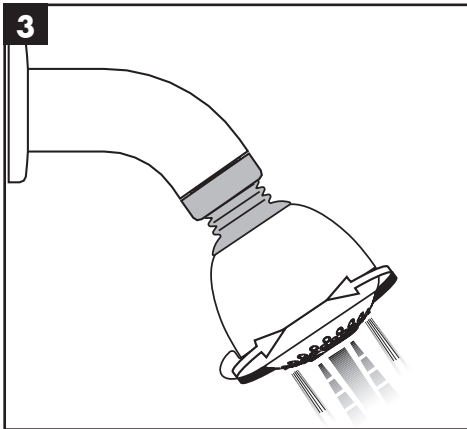
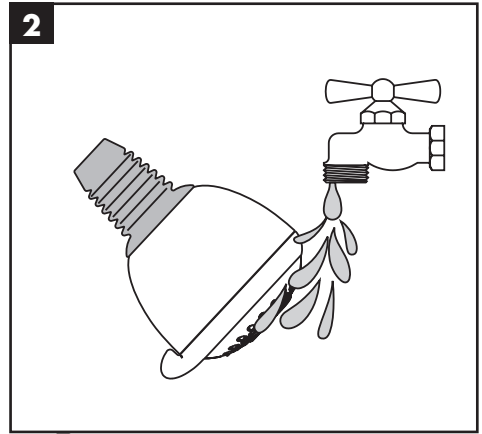
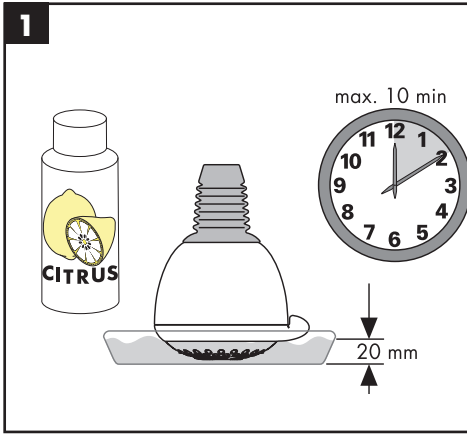



26734000

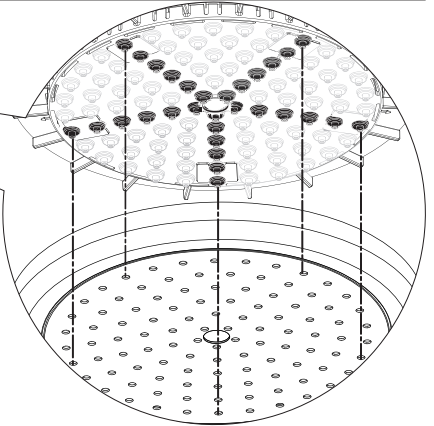
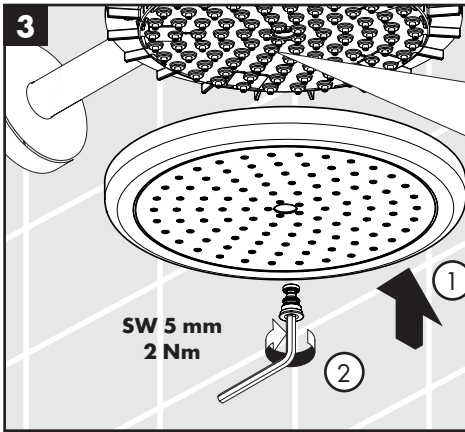
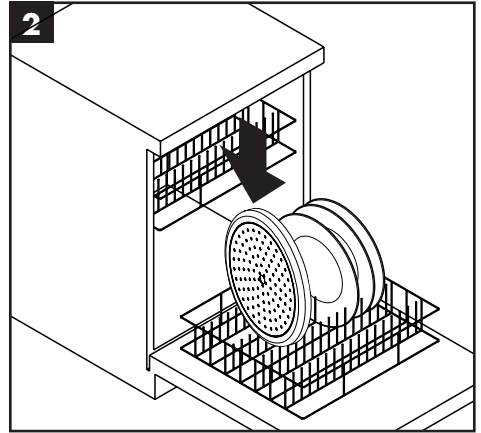
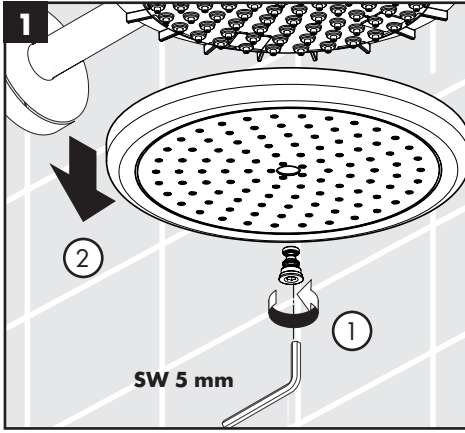



26730000

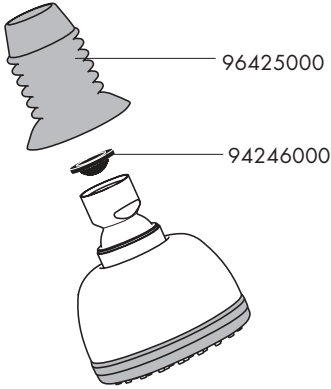

26733000

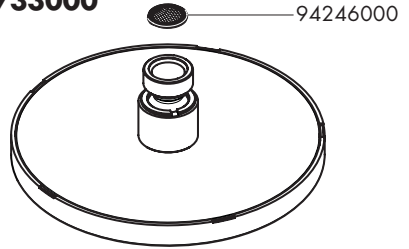

26576000

26576400

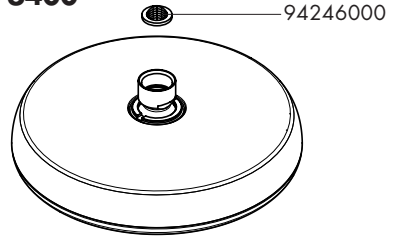

26731000

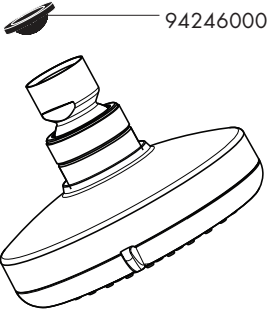

26734000

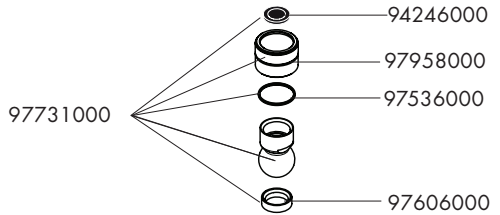

26732000

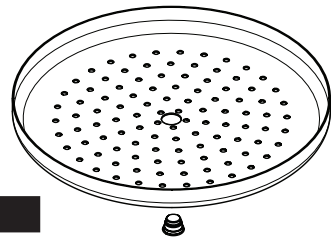
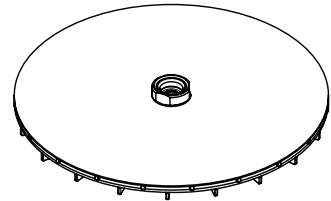
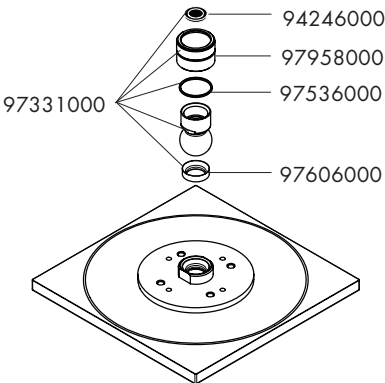

hansgrohe

Hansgrohe, Inc. • 1490 Bluegrass Lakes Parkway • Alpharetta, GA 30004
Tel. 800-334-0455 • Fax 770-360-9887

www.hansgrohe-usa.com